

ADRS Series

Mechanical-Bearing Rotary Stage

High torque output, direct-drive brushless servomotor

Cog-free slotless motor design for outstanding velocity stability

Direct coupled, high-accuracy rotary encoder

Ultra-low-profile minimizes working height

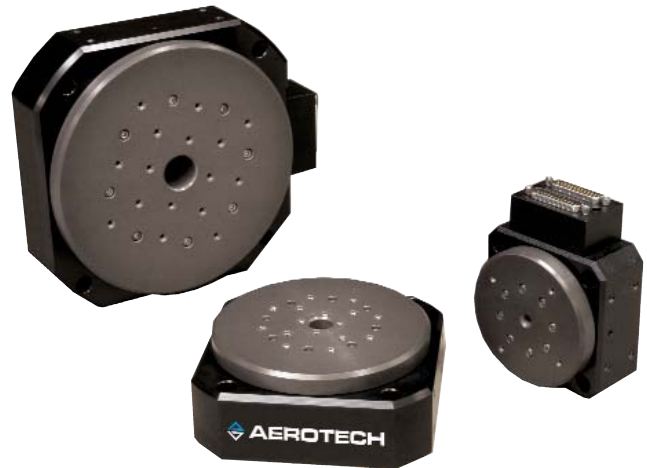

Aerotech's ADRS series with its direct-drive technology and low profile provide a superior alternative to belt- and worm-drive stages.

Compact Package

The design of the ADRS series direct-drive rotary stage was optimized to minimize stage height. The low profile of the stage reduces the effective working height of the system minimizing “stack-up” related errors. In addition to the low overall height, the ADRS series provides a clear aperture that can be used for product feed-through or laser beam delivery.

Brushless Direct-Drive

To maximize positioning performance, the ADRS series utilizes direct-drive brushless motor technology. Direct-drive technology is optimized for 24/7 production environments, as there are no brushes to replace and no gear trains or belts to maintain. Direct drive also provides quicker acceleration and higher top speeds than gear- or belt-driven mechanisms, yielding higher total overall throughput.

The low maintenance and high-throughput characteristics of the ADRS series provide a stage that yields the lowest total cost of ownership.

Slotless Motor

The ADRS series uses a slotless stator design that eliminates torque ripple. This motor technology provides ultra-smooth velocity stability comparable to a high-quality DC brush motor without all the DC motor’s inherent maintenance requirements. Since the slotless motor is directly coupled to the tabletop, velocity disturbances created by toothed belt drives or worm gears are eliminated.

Multiple Configurations

The ADRS series is available in 100 mm, 150 mm, and 200 mm versions. Each stage has options for different motor windings to better match the stage to different operating conditions. The -B winding option provides the highest possible speed operation for a given available bus voltage, while the -A winding gives greater output torque for comparable current levels. Metric and “English” pattern tabletops are available and slotted mounting holes enable attachment to 25 mm and 1 inch hole pattern breadboards. The tabletop of the ADRS series has a labyrinth seal that protects the bearings and encoder from contamination. An optional shaft end seal is available for applications where the bottom of the stage is exposed to contamination.

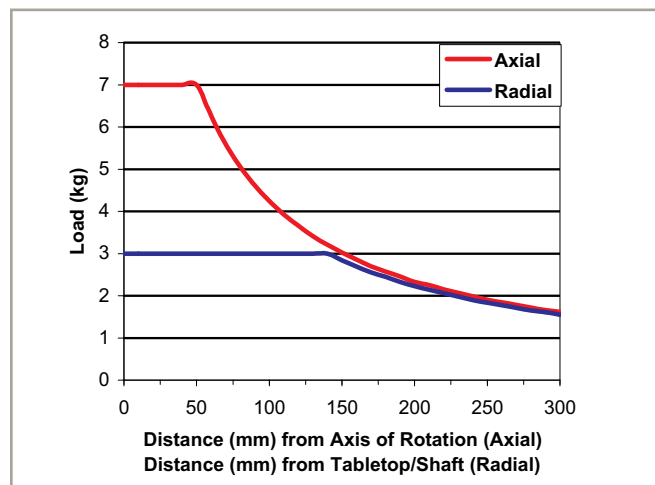

Axial and Radial Cantilevered Load Capability (ADRS100)

ADRS Series SPECIFICATIONS

ADRS Series		ADRS-100	ADRS-150	ADRS-200
Tabletop Diameter		95 mm	140 mm	190 mm
Aperture		6 mm	15 mm	26 mm
Bus Voltage		340 VDC		
Maximum Torque (Continuous)		0.48 N-m	2.36 N-m	5.99 N-m
Max Speed ⁽¹⁾		1500 rpm	600 rpm	600 rpm
Accuracy ⁽²⁾	Uncalibrated	388 μ rad (80 arc sec)		
	Calibrated ⁽³⁾	29.1 μ rad (6 arc sec)		
Repeatability ⁽²⁾		14.6 μ rad (3 arc sec)		
Max Load ⁽⁴⁾	Axial	7 kg	20 kg	40 kg
	Radial	3 kg	10 kg	20 kg
Axial Error Motion ⁽⁵⁾		2 μ m	5 μ m	5 μ m
Radial Error Motion ⁽⁵⁾		3 μ m	5 μ m	5 μ m
Tilt Error Motion		48.5 μ rad (10 arc sec)		
Inertia	Unloaded	0.00038 kg-m ²	0.00242 kg-m ²	0.00843 kg-m ²
Total Mass		2.0 kg	4.3 kg	7.6 kg
Finish	Tabletop	Hardcoat		
	Stage	Black Anodize		

Notes:

1. Maximum speed is based on stage capability. Actual speed may depend on encoder resolution, load, amplifier bus voltage and motor. See the S-series rotary motor for more information.
2. Repeatability and accuracy are dependent on encoder resolution. To achieve the listed specifications, encoder resolution must be 0.36 arc sec or less.
3. With HALAR.
4. Maximum loads are mutually exclusive.
5. For the ADRS-100, error motion specifications are below 700 rpm. Above 700 rpm the max radial error is 5 microns. Errors measured 25 mm above the tabletop.

ADRS Maximum Speeds for Encoder Option

Encoder Option	ADRS-100	ADRS-150	ADRS-200
-AS/-X5/-X10/-X25	1500 rpm	600 rpm	600 rpm
-X50	800 rpm	300 rpm	300 rpm

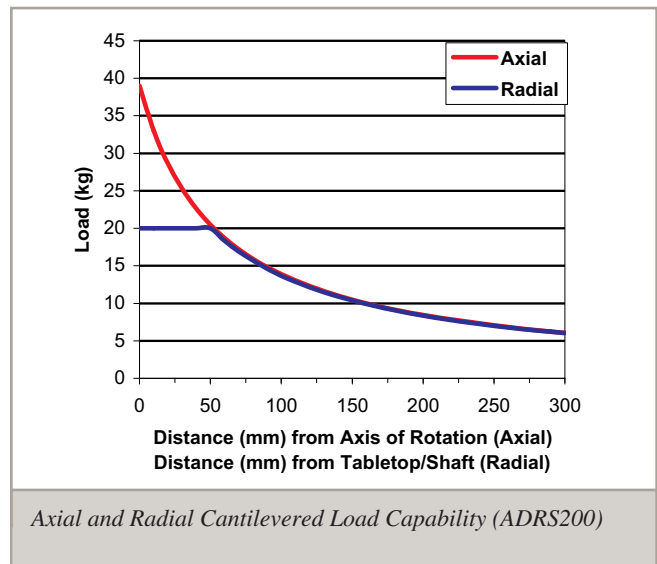
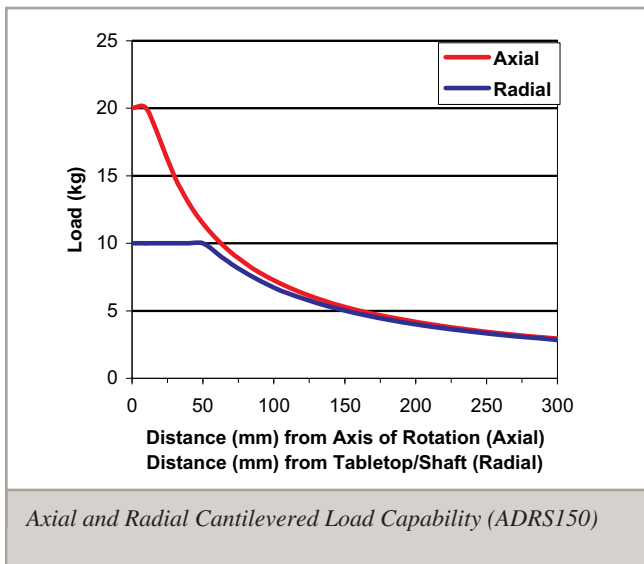

ADRS-200

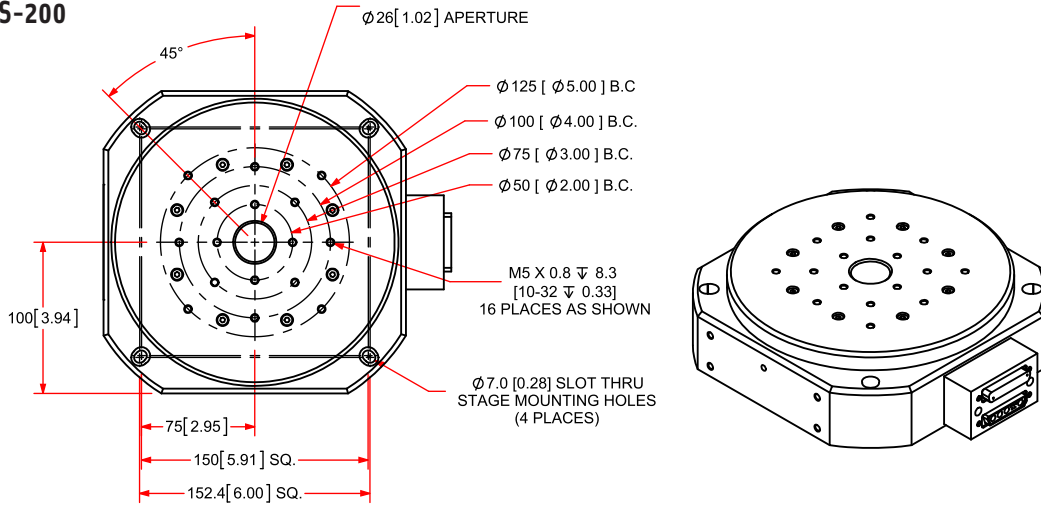

DIMENSIONS - MILLIMETERS [INCHES]

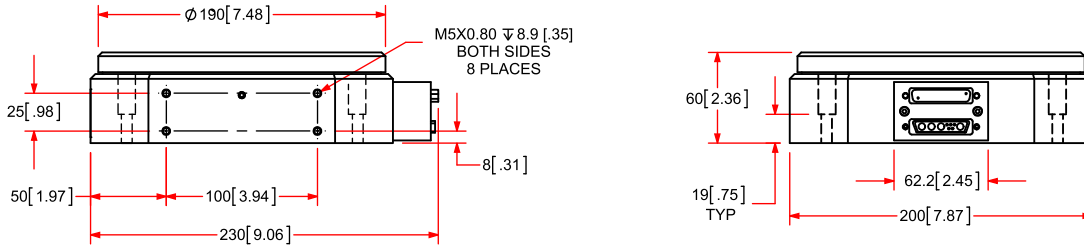

ADRS-150

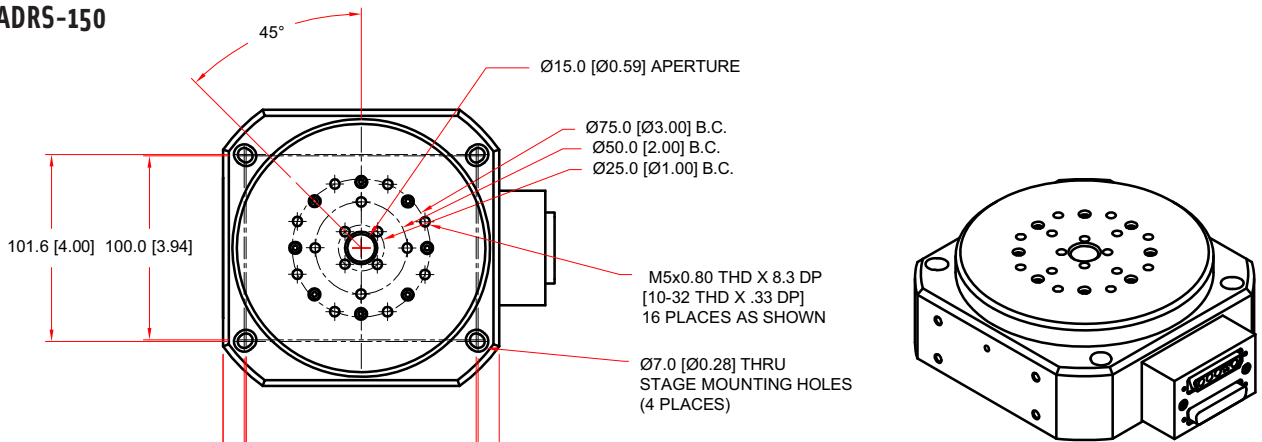

DIMENSIONS - MILLIMETERS [INCHES]

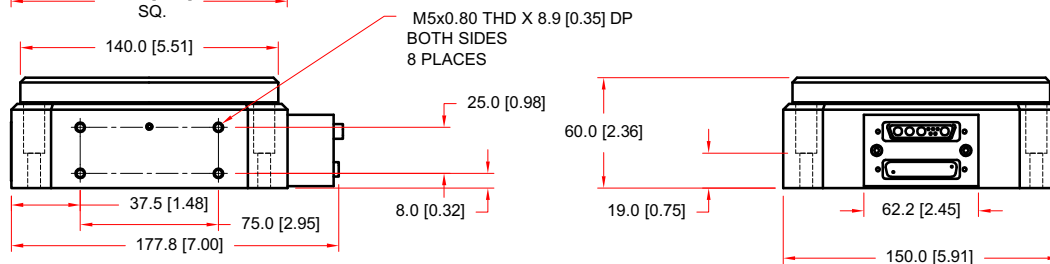

ADRS Series DIMENSIONS and ORDERING INFORMATION

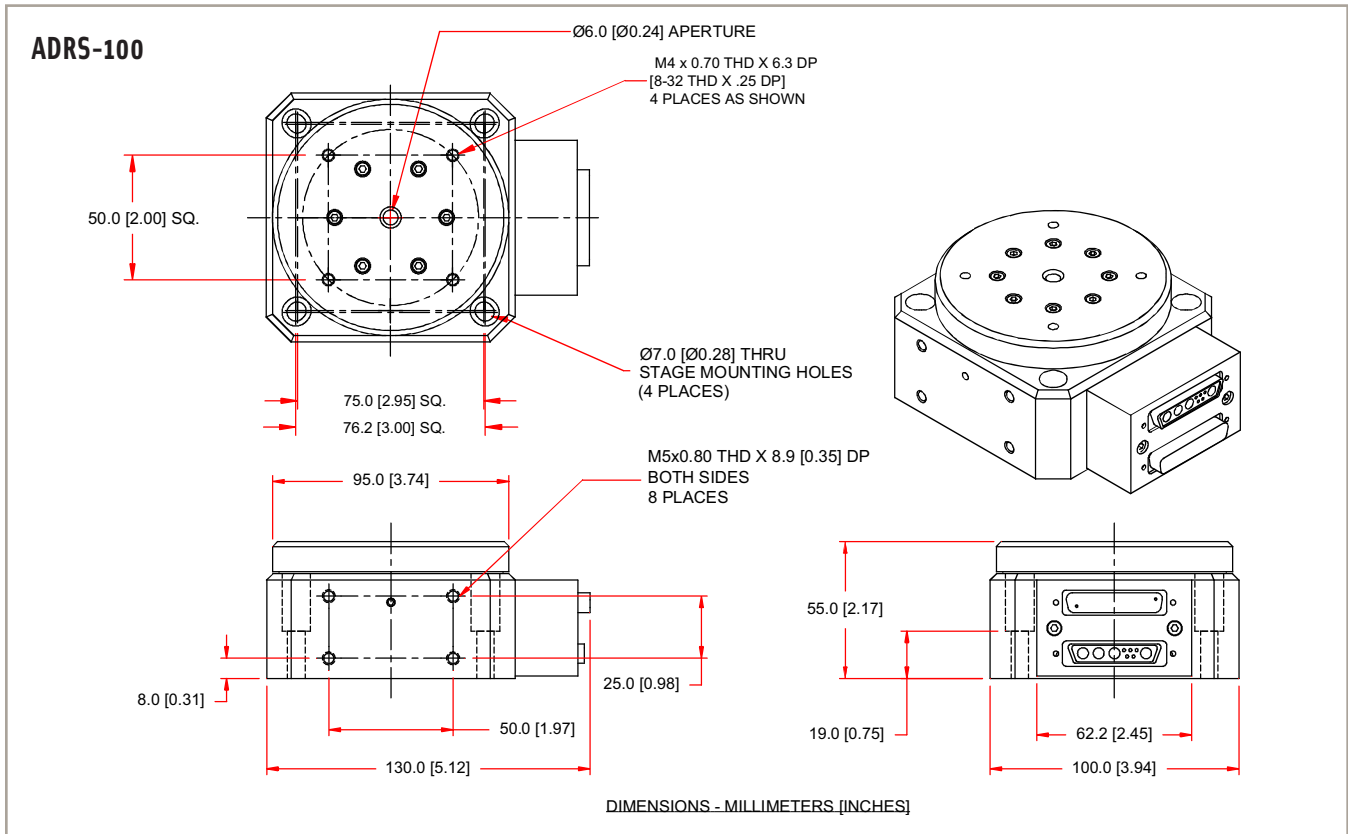

Ordering Example

ADRS	-200	-M	-A	-AS	-S
Series	Width (mm)	Mounting Pattern	Winding Option	Position Transducer	Construction Options
ADRS	-100 -150 -200	-M -U	-A -B	-AS -XX	-S

ADRS Series Direct-Drive Rotary Stage

ADRS-100	100 mm wide direct-drive rotary stage with 0.64 N-m continuous torque output
ADRS-150	150 mm wide direct-drive rotary stage with 2.36 N-m continuous torque output
ADRS-200	200 mm wide direct-drive rotary stage with 5.99 N-m continuous torque output

Mounting Pattern

-M	Metric-dimension mounting pattern and holes
-U	English-dimension mounting pattern and holes

Winding Options

-A	Low speed, high torque-constant winding option
-B	High speed, low torque-constant winding option

Position Transducer

-AS	Standard feedback device; 1 V _{pp} sine wave output; 3600 lines/rev on the ADRS-100; 10,000 lines/rev on ADRS-150/200; final resolution multiplier dependent
-X5	Square wave digital output; 18 arc sec resolution on ADRS-100; 6.48 arc sec resolution on ADRS-150/200
-X10	Square wave digital output; 9 arc sec resolution on ADRS-100; 3.24 arc sec resolution on ADRS-150/200
-X25	Square wave digital output; 3.6 arc sec resolution on ADRS-100; 1.30 arc sec resolution on ADRS-150/200
-X50	Square wave digital output; 1.8 arc sec resolution on ADRS-100; 0.65 arc sec resolution on ADRS-150/200

Note: Digital output encoder signals are synthesized with a 16 MHz clock. Care must be taken to ensure that the encoder sample rate on the controller is at least 16 MHz or higher. Slower clock rates are available on request.

Construction Options (ADRS 150 & 200)

-S	Bottom shaft seal (not available on ADRS-100; ADRS-100 has an integral bottom labyrinth seal)
-NS	No bottom shaft seal